

mini holiday

<http://home.t07.itscom.net/kajie/miniHoliday.htm>

More Files:- <http://home.t07.itscom.net/kajie/List.htm>

The main wing type is AG12, and the performance of the Micro Monkey is quite good, so I thought about making the airframe a little larger, and I'm thinking of making one that is about 0.71 times the size of Musasino Holliday. Of course, the larger the aircraft, the better the performance, but there is also a physical balance, so I think a wingspan of about 75cm is just right. (16/06/08)

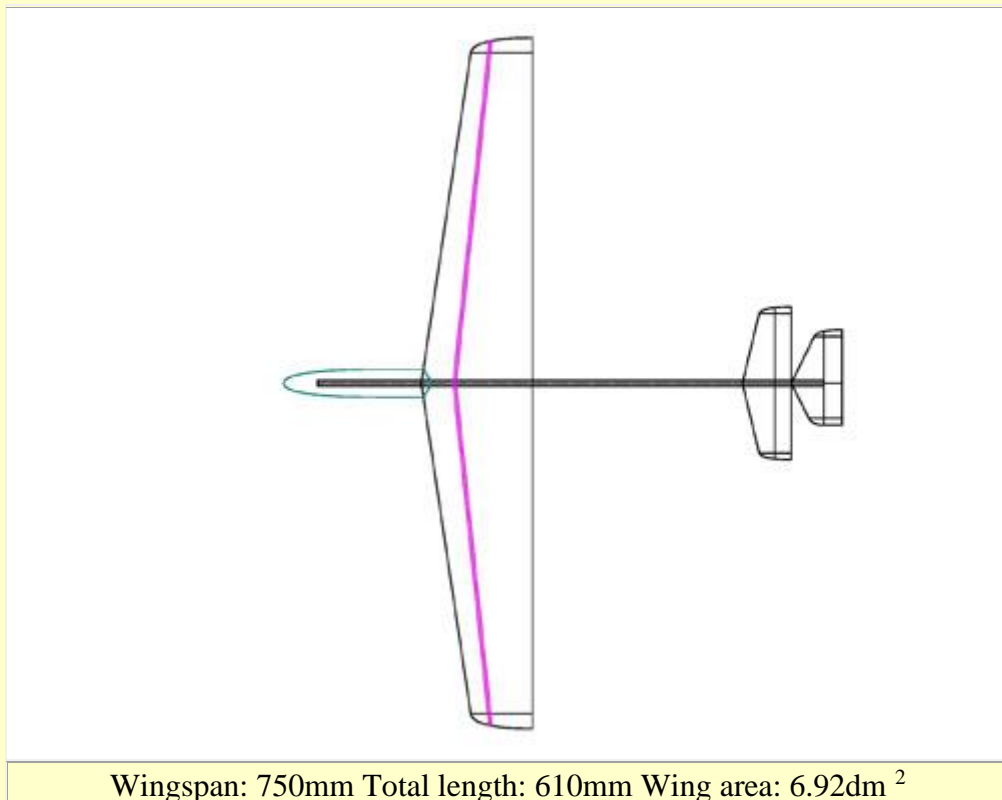

I used up the 900 x 900 (30mm thick) blue foam that Mr. N bought for me. Even if the voltage is changed or the weight of the weight is changed, the shallow streak pattern in the wing span direction cannot be removed. The taper ratio may be too large, but the exact cause is unknown. At this rate, no matter how much time passes, I can't fly, so I decided to compromise around here. The main specifications of the current foam cutter are as follows. The hot wire is $\phi 0.45$ stainless steel wire. Voltage is about 13V. The weight of the arm is about 70g. It takes about 30 seconds to cut. (16/07/24)

There is no chance to fly with friends. I went out to fly on September 4th, but the wind was strong and it was not a situation to adjust. After throwing it a few times, I got the impression that it glides longer than the Micro Monkey. The cause of this is not well understood. (16/09/04)

I tried throwing it with a 0.4mm veneer because the mounting angle might be too large, but it actually got worse. Return the mounting angle and try to move the center of gravity forward. The return after throwing up has disappeared, but the gliding is not stable. While doing so, the nose pod was crushed. There is still a long way to go...(16/09/16)

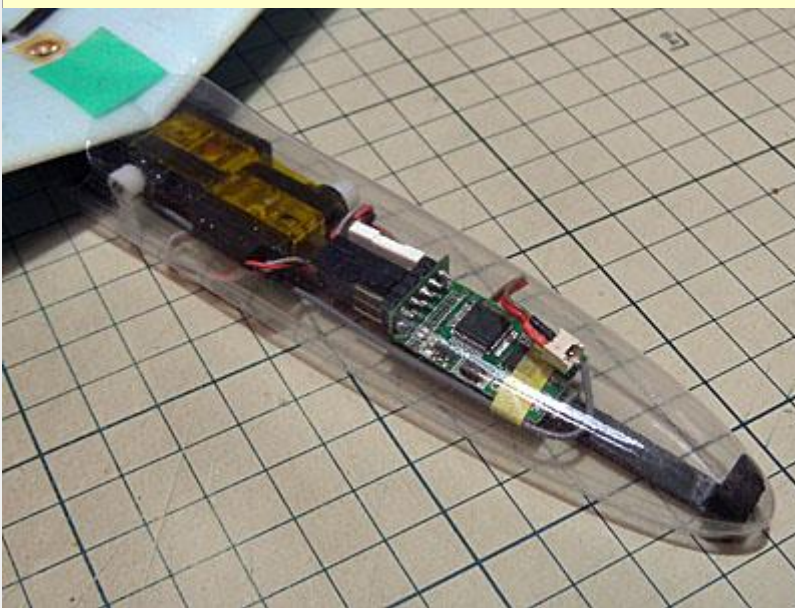

17/01/07: Pod Refurbishment
2

Affix a black medium density sponge strip to the tip to stop play in the front pod. On the rear side, cut off the old lower pod about 3 cm and leave it. Green rough surface tape is used to fix the pod itself. This makes no difference in practice.

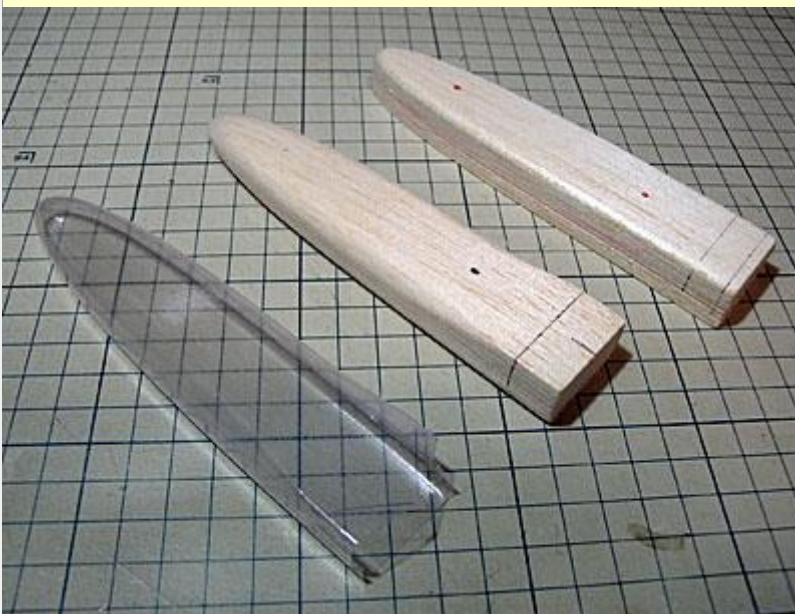

17/01/04: Pod Refurbishment

I tried it yesterday for the first time in a while. When you can't catch it by hand, the sand gets stuck in the gap between the pods.

Cut the upper and lower pods so that they are overlapped by about 3 mm, and apply adhesive for PVC pipes to the gaps. It's unified

for the time being, but is it a headlong landing? would not be able to withstand

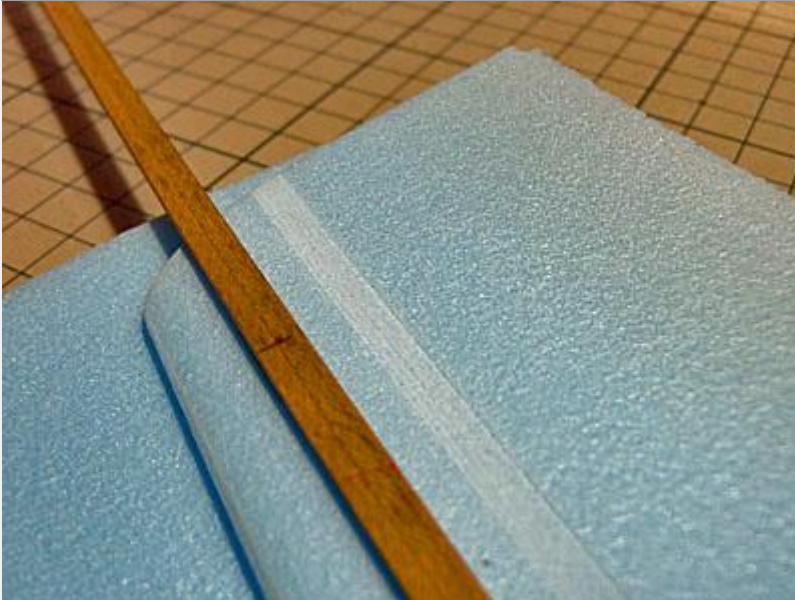

16/09/17: Spur groove

It's a little hard to see, but a good ditch was dug. To the left of the ditch is a cypress guide.



16/09/17: Spar grooving

Attach #150 sandpaper to 3mm balsa, and attach double-sided tape on both sides with the protective paper attached. This gives a depth of around 0.2mm.

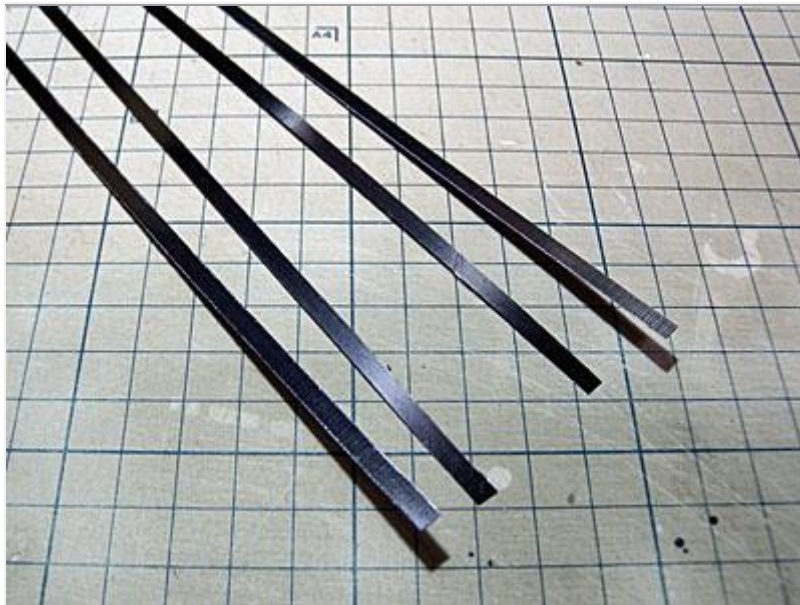

16/09/17: Spur clipping

Cut a carbon sheet with a thickness of 0.2mm into a width of 4mm. Use a P cutter. I can't cut it as I thought.



16/09/11: Clipping with new template

It's been raining since this morning. I can't fly.

Cutting out with the new template is going well.

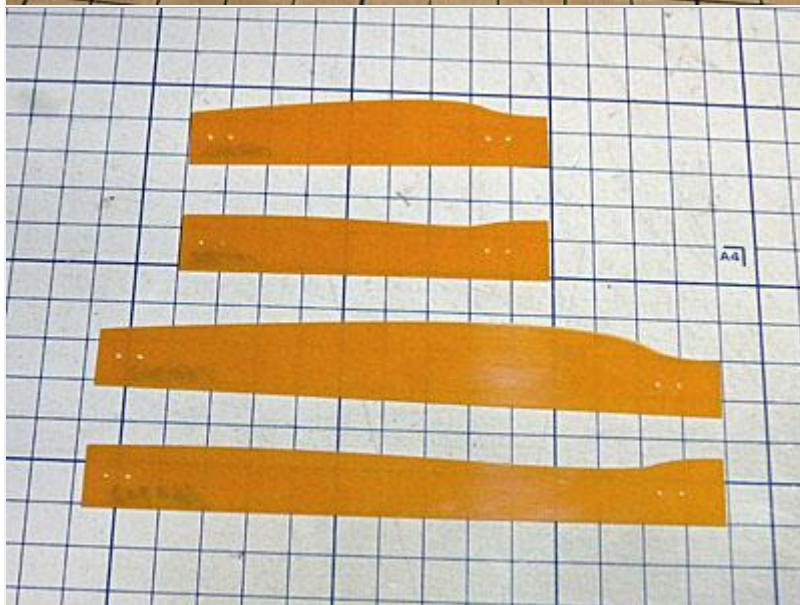

16/09/04: New template

I got 1mm thick Bakelite, so I made a template immediately. When cut with this, the shallow streaky pattern that occurred with veneer + aluminum tape does not occur. Bakelite may be more slippery.



16/08/21: I'm ready to fly...

Gross weight 55.0g. Wing loading $7.95\text{g}/\text{dm}^2$. The latter half of the pod is still unfinished, so the weight will still increase.

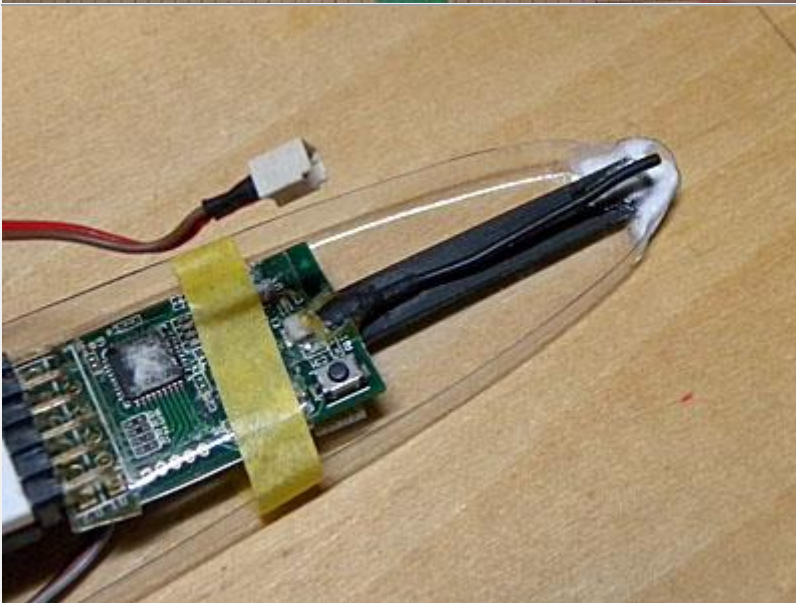

16/08/21: Pod Tip

The tip was supposed to be instantly reinforced with a microballoon, but the heat generated during hardening distorted the PVC pod.

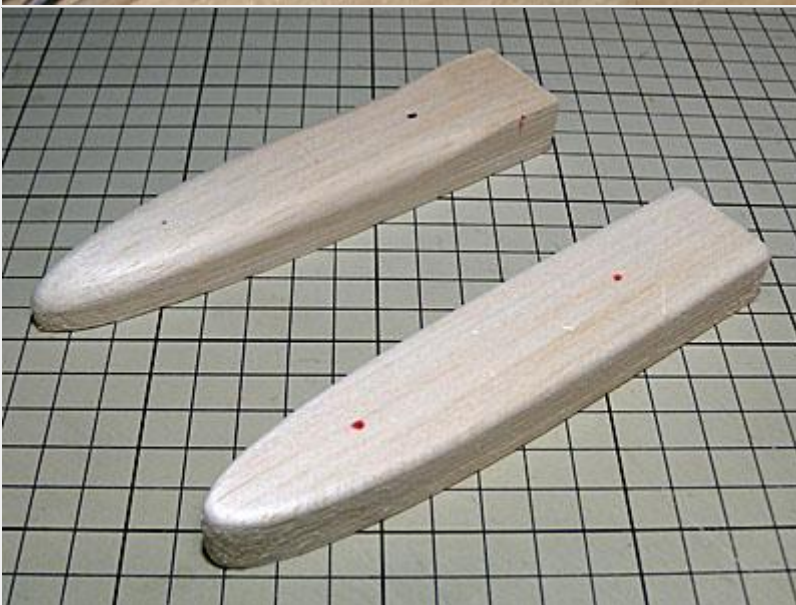

16/08/21: Pod type

The pod is divided into upper and lower parts. Two layers of 8mm balsa are cut out and scraped to look like it, and the transparent PVC is molded with vacuform.

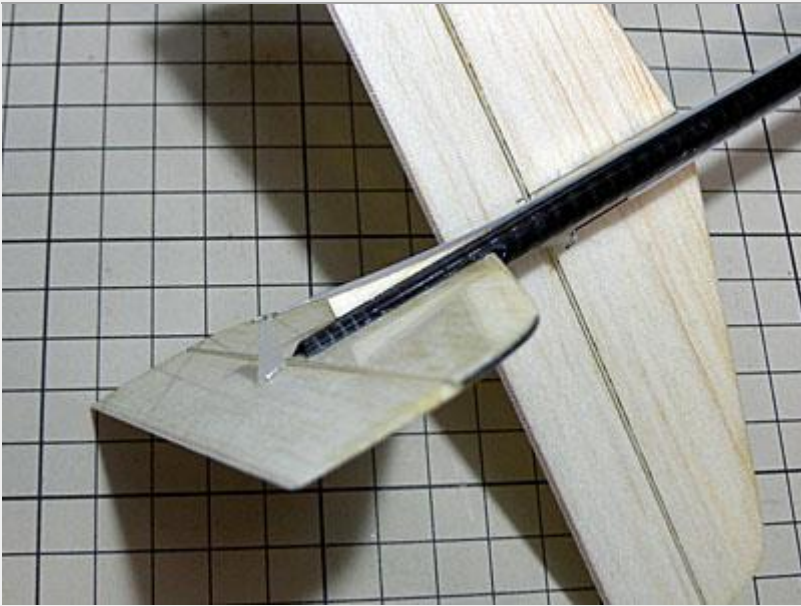

16/08/13: State of the tail

The horn is cut out from a 0.5mm FRP board.

Current weight; total 52.6g
fuselage 23.6g

battery 150mAh 4.1g

main wing 24.9g

(including wings)



16/08/13: Loading (lower side)

Since the antenna case was removed, the boom should be about 20mm shorter than planned.

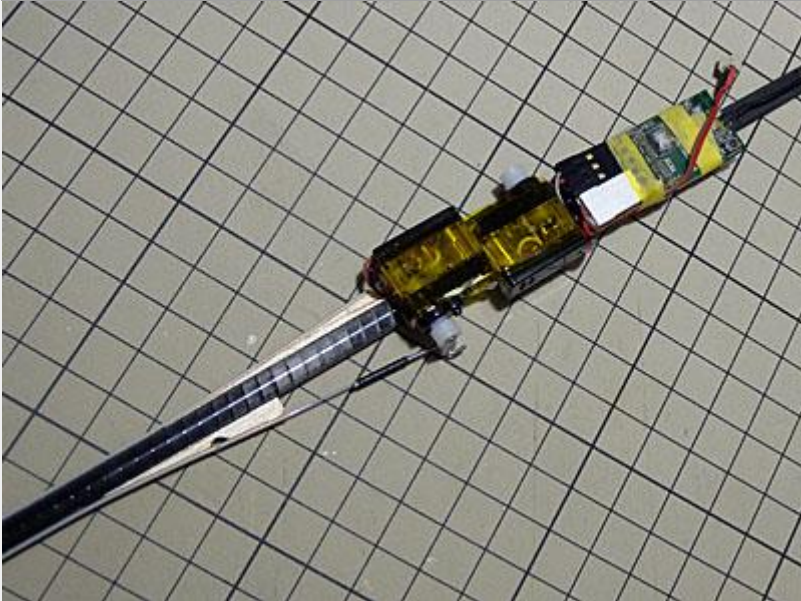

16/08/13: Load (upper)

The servo uses S034D and the receiver uses V8R4. The rod is 0.45mm stainless steel wire. Outer skin is Teflon tube.

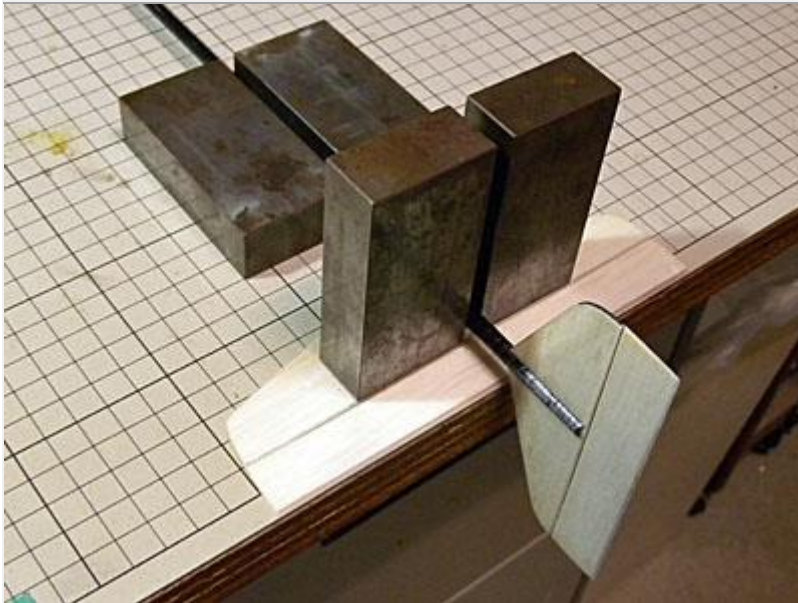

16/08/11: Fixing the tail

The boom is a $\phi 6$ carbon pipe. Glue carefully so that each wing is perpendicular.

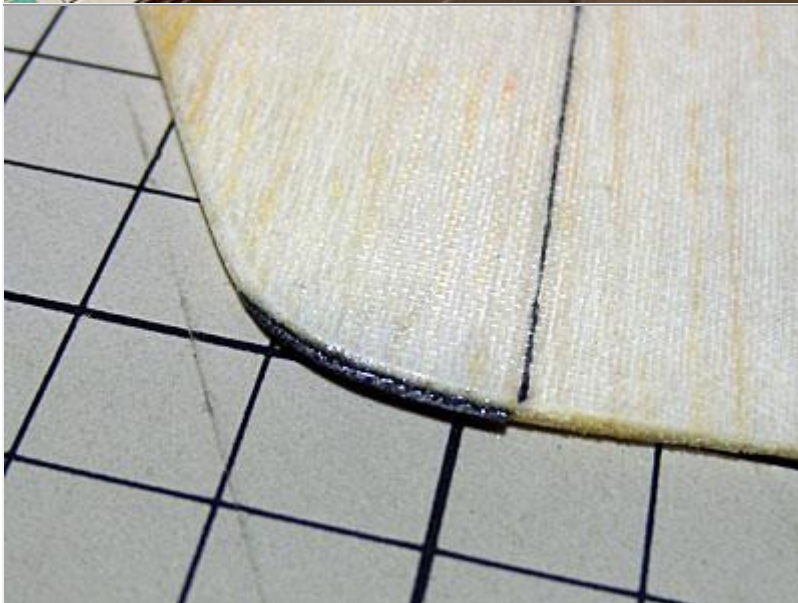

16/08/11: Vertical tail sled

Make a cut on the bottom surface and insert 0.2 carbon and fasten it instantly.



16/08/11: Wing screw

The main wing retaining screws use polycarbonate M3 countersunk screws. A normal nut cannot be used because the gap between the wing bases is narrow. Cut a 2mm FRP plate into 9x9 pieces and put an M3 tap in the center.

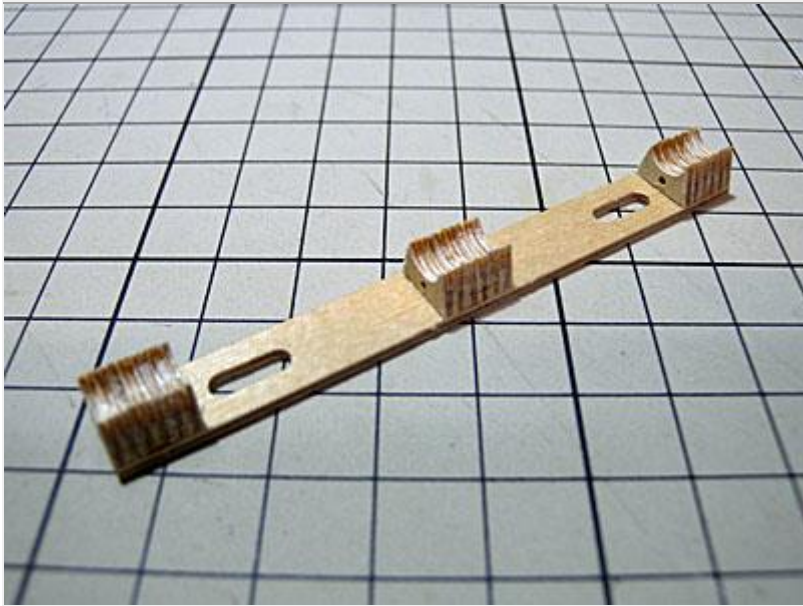

16/08/07: Wing platform
1.6 and 3.0mm aeronautical veneers were used.

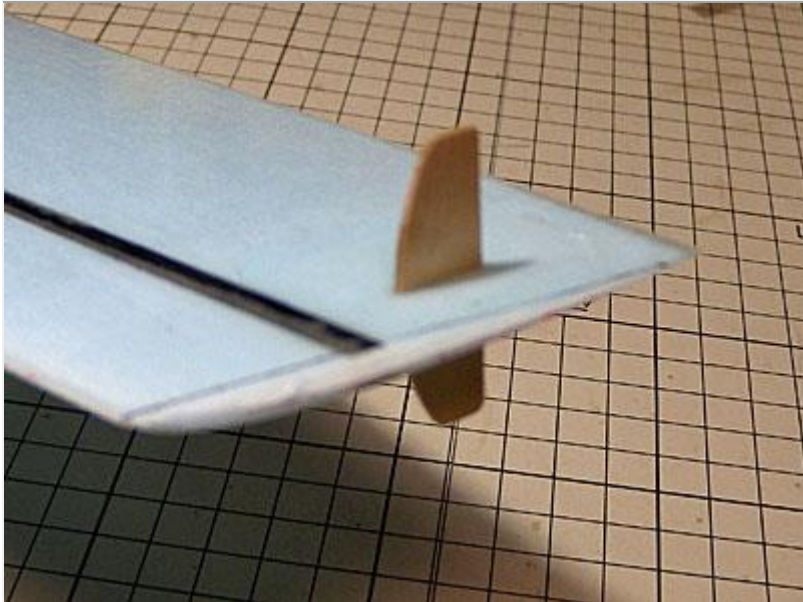

16/08/07: Peg
Made from 1.0 aviation veneer. Reinforce the perimeter with glass. Completed weight of the main wing is 22.6g.



16/08/07: Pieces for wing retainers
Manufactured by stacking aviation veneers. Fasten with M3 bolts and fit into the holes drilled in the main wing to fix it instantly. Reinforce joints with glass.



16/08/07: Joining the main wing

The dihedral angle is 11 degrees on the lower surface.

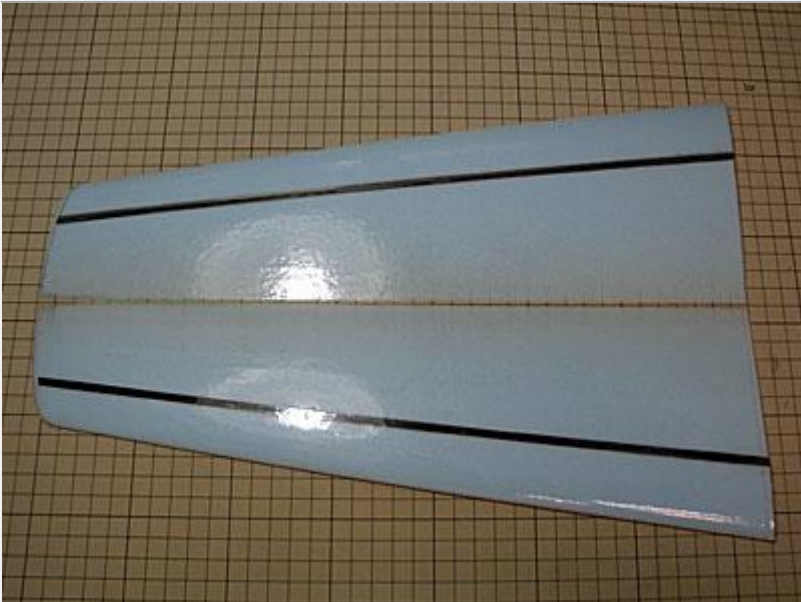

16/08/06: Main wing bagging completed

Both wings were finished with about 10g.



16/08/06: Wing bagging

An A3 bag is not long enough, so add another 20 cm of the same bag. I pasted it with a 5 cm wide transparent tape, but there is no problem. Epoxy measurement uses a scale of 0.01g unit, but if you carelessly turn off the automatic power off function,

you need to poke the scale with your finger from time to time so that the scale does not fall asleep.

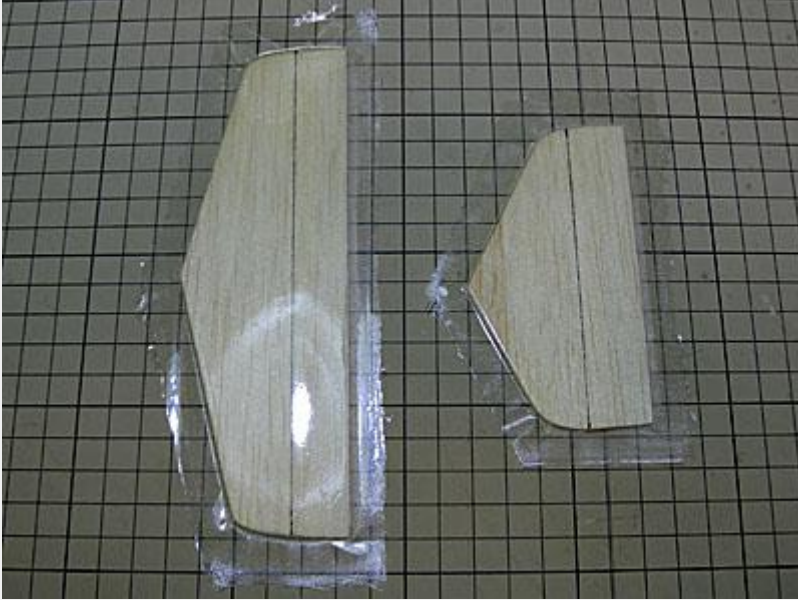

16/07/31: Tail wing bagging completed

Uses 1.5 balsa. This time, I put a PPP sheet on top of the flower shop film, so the surface is smooth.



16/07/31: tail bagging

Bagging work for the first time in a while. Having a hard time remembering the steps. Epoxy hardens quickly because of the high temperature. Set in the morning and finished in the evening.

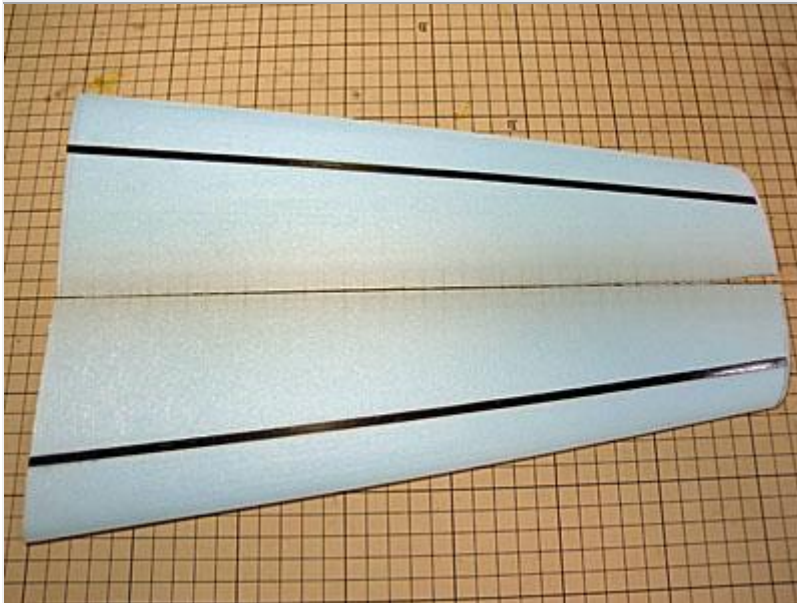

16/07/24: Apply spars

Cut a 0.2mm thick carbon sheet into 4mm width and stick it on the upper and lower surfaces of the wing with Nakano CA.

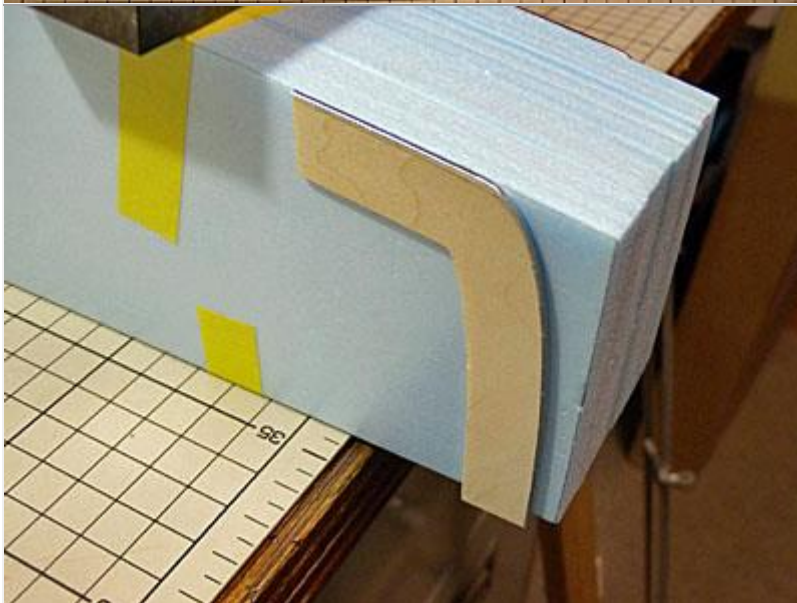

16/07/24: Wing tip cut

Make a jig with 1mm veneer and put aluminum tape on it.

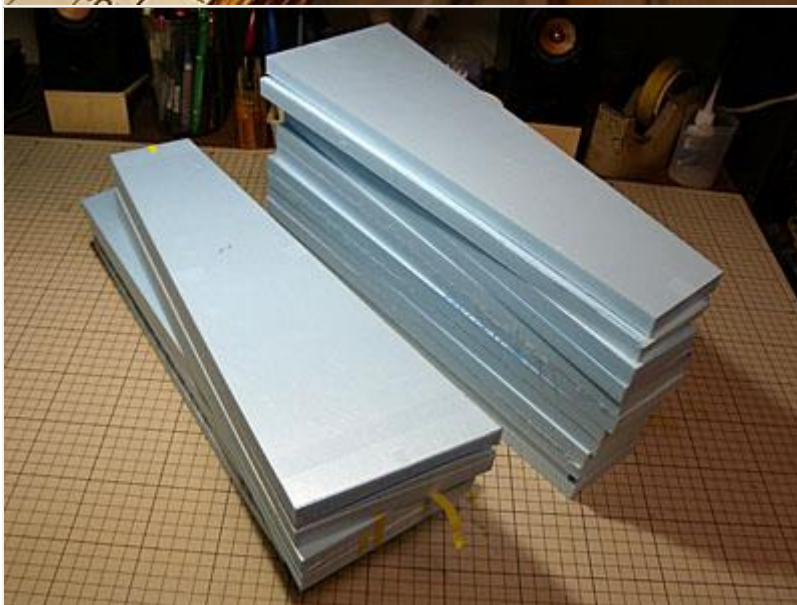

16/06/25: Scrap pile

A $\phi 0.35$ stainless steel wire is used for the hot wire, but the tension is too high and it gradually extends. I had no choice but to change to a tungsten wire of $\phi 0.30$, but I could not cut it cleanly. I was a little tired, so I took a short break.



16/06/18: Cutting out the main wing

30mm thick blue foam is used. The cutter used was modified to a width of 60 cm.

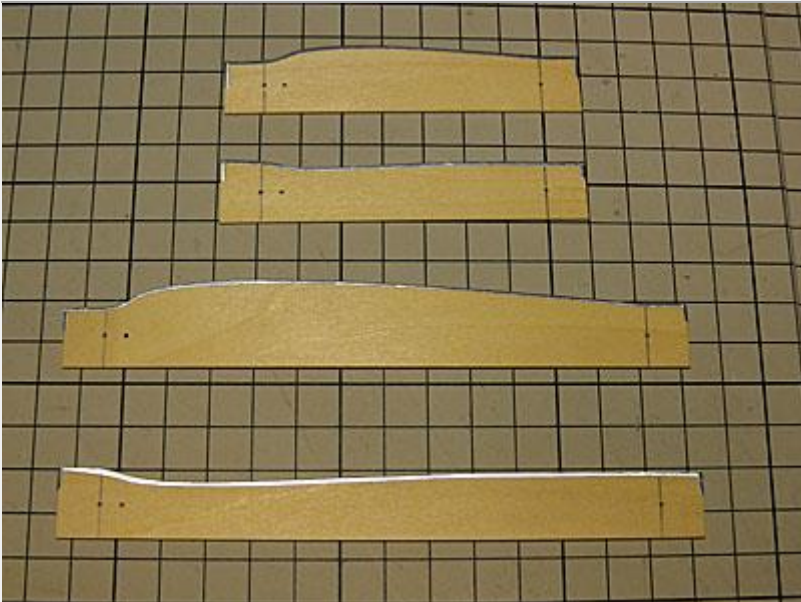

16/06/13: Airfoil template

The airfoil is AG12. Cut out from 1mm syna veneer. Attach aluminum tape to the top.